

BLUE STAR GROUP

PRODUCT WEIGHTS AND DIMENSIONS DATA

DIMENSIONS / WEIGHTS	BRELLA LIGHTS (BL008)	BRELLA LIGHTS (BL078)	MAUI SUNSET LIGHTS (MS008)	5" BRELLA VASE (BL05 / OPAQUE)	5" BRELLA VASE (BL05 / TRANSLUCENT)	10" BRELLA VASE (BL10 / OPAQUE)	10" BRELLA VASE (BL10 / TRANSLUCENT)
CASE QUANTITY - Units	12	12	12	12	12	12	12
UNIT BOX DIMENSIONS (IN)	12 x 12 x 3	12 x 12 x 3	10 x 8 x 2	6 x 5.25 x 5.25	6 x 5.25 x 5.25	6.75 x 10.375 x 6	6.75 x 10.375 x 6
UNIT BOX DIMENSIONS (FT)	1 x 1 x 0.25	1 x 1 x 0.25	0.8333 x 0.6666 x 0.1666	0.5 x 0.4375 x 0.4375	0.5 x 0.4375 x 0.4375	0.5625 x 0.8646 x 0.5	0.5625 x 0.8646 x 0.5
UNIT BOX DIMENSIONS (CM)	30.48 x 30.48 x 7.62	30.48 x 30.48 x 7.62	25.4 x 20.32 x 5.08	15.24 x 13.335 x 13.335	15.24 x 13.335 x 13.335	17.145 x 26.353 x 15.24	17.145 x 26.353 x 15.24
UNIT BOX DIMENSIONS (CIN)	432	432	160	165.375	165.375	420.188	420.188
UNIT BOX DIMENSIONS (CFT)	0.25	0.25	.09254	0.0957	0.0957	0.24317	0.24317
UNIT BOX DIMENSIONS (CCM)	7079.2	7079.2	2621.9	2710	2710	6885.77	6885.77
UNIT BOX DIMENSIONS (CBM)	0.70792	0.70792	0.26219	0.271	0.271	0.68858	0.68858
CASE DIMENSIONS (IN)	24.606 x 19.134 x 12.756	18.425 x 12.52 x 24.882	16.735 x 12.874 x 10.748	16.772 x 12.598 x 11.417	16.772 x 12.598 x 11.417	18.752 x 14 x 21.5	18.752 x 14 x 21.5
CASE DIMENSIONS (FT)	2.0505 x 1.5945 x 1.063	1.5354 x 1.0433 x 2.0735	1.3946 x 1.0728 x 0.8957	1.3977 x 1.0498 x 0.9514	1.3977 x 1.0498 x 0.9514	1.5627 x 1.1667 x 1.7917	1.5627 x 1.1667 x 1.7917
CASE DIMENSIONS (CM)	62.4992 x 48.6003 x 32.4002	46.7995 x 31.8008 x 63.2003	42.5069 x 32.67 x 27.3	42.6009 x 32 x 29	42.6009 x 32 x 29	47.6301 x 35.56 x 54.61	47.6301 x 35.56 x 54.61
CASE DIMENSIONS (CIN)	6005.6676	5739.8046	2315.6177	2412.3396	2412.3396	5644.352	5644.352
CASE DIMENSIONS (CFT)	3.4755	3.3215	1.34008	1.39599	1.39599	3.26663	3.26663
CASE DIMENSIONS (CCM)	98414.95300	94058.57300	37911.52000	39533.63500	39533.63500	92494.39300	92494.39300
CASE DIMENSIONS (CBM)	0.98415	0.94059	0.37912	0.39534	0.39534	0.92494	0.92494
UNIT WEIGHT (LBS)		2.125	1.21875	0.34375	0.3375	1.11875	1.0875
UNIT WEIGHT (KG)		0.96388	0.55282	0.15592	0.15309	0.50746	0.49328
NW - CASE WEIGHT (LBS)	31.747	25.5	14.625	4.125	4.05	13.425	13.05
NW - CASE WEIGHT (KG)	14.4	11.56661	6.63379	1.87107	1.83705	6.08948	5.91938
GW - CASE WEIGHT (LBS)	34.883	35.053	16.755	12.346	12.346	22.421	22.421
GW - CASE WEIGHT (KG)	15.8	15.89977	7.59994	5.60005	5.60005	10.16999	10.16999
CONTAINER QUANTITY (20') - Units	-	-	-	-	-	-	-
CONTAINER QUANTITY (40') - Units	-	-	-	-	-	-	-
CONTAINER QUANTITY (40'-HQ) - Units	-	7980.00000	-	21696.00000	21696.00000	9132.00000	9132.00000
CONTAINER QUANTITY (20') - Cases	-	-	-	-	-	-	-
CONTAINER QUANTITY (40') - Cases	-	-	-	-	-	-	-
CONTAINER QUANTITY (40'-HQ) - Cases	-	665.00000	-	1808.00000	1808.00000	761.00000	761.00000
BRELLA VASE FLUID CAPACITY				2 @ 1.66 Cups / 400 ML	2 @ 1.66 Cups / 400 ML	2 @ 4 Cups / 900 ML	2 @ 4 Cups / 900 ML
MISC. BRELLA VASE INFORMATION							
- SHIPPING CLASS - T.S.U.S.A. NO.	NMFC "XX" Plastic, Household Articles - Item "XX" 39240.90.5500 5062						
MISC. BRELLA LIGHTS INFORMATION							
- SHIPPING CLASS - T.S.U.S.A. NO.	NMFC "100" Electrical Lighting, Other Electrical Lamps & Light Fixtures - Item "109886" 9405.40.8000 9243 7980						
MISC. MAUI SUNSET LIGHTS INFORMATION							
- SHIPPING CLASS - T.S.U.S.A. NO.	NMFC "100" Electrical Lighting, Other Electrical Lamps & Light Fixtures - Item "109886" 9405.40.8000 9243 7980						

Dimensions and weights indicated above are as printed on Master Cartons.
 Converted figures are predicated on the printed Master Carton labeling.
 Actual numbers may vary.

BLUE STAR GROUP PRODUCT WEIGHTS AND DIMENSIONS DATA

DIMENSIONS / WEIGHTS	36' ROUND Table (TMC-)	36' SQUARE Table (TMV-)	42' OVAL Table (TMB-)	Side Chair - (Pair) (CW)	Arm Chair - (Pair) (AW)	7.5' OTWB (7)	9' OTWB (9)	Base (CCB-2)
CARTON QUANTITY - Units	1	1	1	2	2	1	1	1
UNIT CARTON DIMENSIONS (IN)	38.5 x 31.75 x 8.5	39 x 31.75 x 8.75	44.25 x 31.75 x 8.5	44.5 x 19.5 x 10.25	45 x 25.5 x 12	64 x 5.71 x 5.71	72 x 5.71 x 5.71	20.25 x 17.5 x 2.5
UNIT CARTON DIMENSIONS (FT)	3.208 x 2.646 x 0.708	3.25 x 2.646 x 0.729	3.688 x 2.646 x 0.708	3.707 x 1.625 x 0.854	3.75 x 2.125 x 1	5.33 x 0.4758 x 0.4758	6 x 0.4758 x 0.4758	1.688 x 1.458 x 0.208
UNIT CARTON DIMENSIONS (CM)	97.79 x 80.645 x 21.59	99.06 x 80.645 x 22.225	112.395 x 80.645 x 21.59	113.03 x 49.53 x 26.035	114.3 x 64.77 x 30.48	162.56 x 14.503 x 14.503	182.88 x 14.503 x 14.503	51.435 x 44.45 x 6.35
UNIT CARTON DIMENSIONS (CIN)	10390.187	10834.687	11941.968	8894.438	13770.0	2086.662	2347.4952	885.938
UNIT CARTON DIMENSIONS (CFT)	6.0097	6.269	6.909	5.1444	7.9688	1.2066	1.3583	0.5119
UNIT CARTON DIMENSIONS (CCM)	170264.66	177548.71	195693.8	145753.71	225649.87	34192.383	38466.43	14517.914
UNIT CARTON DIMENSIONS (CBM)	0.17026	0.17755	0.19569	0.14575	0.22565	0.34192	0.38466	0.14518
NW - UNIT WEIGHT (LBS)	25	25	27.5	19 / 9.5 ea.	28 / 14 ea.	9	10	43
NW - UNIT WEIGHT (KG)	11.3398	11.3398	12.4738	8.6182 / 4.3091 ea.	12.7006 / 6.3503 ea.	4.0823	4.5359	19.5045
GW - CARTON WEIGHT (LBS)	28	31	35	28	39	11	13	45
GW - CARTON WEIGHT (KG)	12.7006	14.0614	15.8757	12.7006	17.6901	4.9895	5.8967	20.4117
CONTAINER QUANTITY (20') - Units								
CONTAINER QUANTITY (40') - Units								
CONTAINER QUANTITY (40'-HQ) - Units								
MISC. OTWB INFORMATION								
- MATERIAL - (ALUMINUM)	NMFC "85" Umbrella / Patio - Item "188080-02"							
- SHIPPING CLASS	6601.10.0000							
- T.S.U.S.A. NO.	Rate: 6.5% Merch. Process Fee: 0.21% Harbor Fee: 0.125% Total Rate: 6.835%							
MISC. TM INFORMATION								
- MATERIAL - (NYATOH)	NMFC "85" Folding Chairs - Item "80565" - Knocked down in boxes.							
- SHIPPING CLASS	NMFC "85" Wooden Tables - Item "82130" - Knocked down in boxes. Allows one (1) Base per table.							
MISC. BASE INFORMATION								
- MATERIAL - (CAST IRON)	NMFC "60" Umbrella Base - Item # 22060 // One (1) allowed per wooden table above.							
- SHIPPING CLASS	6603.90.8000							
- T.S.U.S.A. NO.	Rate: 5.2% Merch. Process Fee: 0.21% Harbor Fee: 0.125% Total Rate: 5.535%							

Dimensions and weights indicated above are as printed on Master Cartons.
 Converted figures are predicated on the printed Master Carton labeling.
 Actual numbers may vary.

BLUE STAR GROUP PRODUCT WEIGHTS AND MEASURES

<p>9' OFF-THE-WALL BRELLA - w/canopy</p> <p>Carton Box : Double Wall Material : Aluminium Finish : Champaign Unit Size : 8.75 x 4.5 x 8.25 ft 274.32 x 137.16 x 213.36 cm</p> <p>Per Carton: 1 Carton Size : 5.97 x 0.48 x 0.48 ft / 1.375 cft 181.97 x 14.63 x 14.63 cm / 0.039 cbm</p> <p>GW/NW : 16.72 / 12.32 lbs 7.58 / 5.59 kgs</p> <p>NMFC: "85" Umbrella/Patio - Item "188080-S2"</p>	<p>7.5' OFF-THE-WALL BRELLA - w/canopy</p> <p>Carton Box : Double Wall Material : Aluminium Finish : Champaign Unit Size : 7.25 x 3.75 x 7 ft 220.98 x 114.3 x 213.36 cm</p> <p>Per Carton: 1 Carton Size : 5.25 x 0.48 x 0.48 ft / 1.21 cft 160.02 x 14.63 x 14.63 cm / 0.034 cbm</p> <p>GW/NW : 14.74 / 10.34 lbs. 6.69 / 4.69 kgs</p> <p>NMFC: "85" Umbrella/Patio - Item "188080-S2"</p>
<p>CALEO - 36" Half Square Table</p> <p>Carton Box : Thick 5 ply carton box Wood : Nyatoh Finishing : PU Teak Oil Unit Size : 3 x 1.83 x 2.33 ft 91.44 x 55.88 x 71.12 cm</p> <p>Per Carton: 1 Carton Size : 0.69 x 2.59 x 3.12 ft / 5.57 cft 21 x 79 x 95 cm / 0.157 cbm</p> <p>GW/NW : 30.87 / 26.46 lbs 14 / 12 kgs</p> <p>NMFC: "85" Wooden Tables - Item "82130". - Knock down in box / Allows one (1) base per table</p>	<p>VILLA - 36" Half Round Table</p> <p>Carton Box : Thick 5 ply carton box Wood : Nyatoh Finishing : PU Teak Oil Unit Size : 3 x 2.17 x 2.33 ft 91.44 x 66.04 x 71.12 cm</p> <p>Per Carton: 1 Carton Size : 0.69 x 2.59 x 3.12 ft / 5.57 cft 21 x 79 x 95 cm / 0.157 cbm</p> <p>GW/NW : 30.87 / 26.46 lbs 14 / 12 kgs</p> <p>NMFC: "85" Wooden Tables - Item "82130". - Knock down in box / Allows one (1) base per table</p>
<p>BISTRO - 42" Half Oval Table</p> <p>Carton Box : Thick 5 ply carton box Wood : Nyatoh Finishing : PU Teak Oil Unit Size : 3.5 x 2.5 x 2.33 ft 106.68 x 76.2 x 71.12 cm</p> <p>Per Carton: 1 Carton Size : 0.69 x 2.59 x 3.61 ft / 6.45 cft 21 x 79 x 110 cm / 0.183 cbm</p> <p>GW/NW : 35.28 / 30.87 lbs 16 / 14 kgs</p> <p>NMFC: "85" Wooden Tables - Item "82130". - Knock down in box / Allows one (1) base per table</p>	<p>Custom Cast Base</p> <p>Carton Box : Thick 5 ply carton box Material : Cast Iron Finish : Black Unit Size : 1.64 x 1.15 x 0.869 ft 50 x 35 x 26.5 cm</p> <p>Per Carton: 1 Carton Size : 1.69 x 1.39 x .295 ft / 0.69 cft 51.51 x 42.37 x 8.9916 cm / 0.02 cbm</p> <p>GW/NW : 43.3 / 40 lb 19.64 / 18.14 kgs</p> <p>NMFC: One (1) Base allowed per Wooden Table.</p>
<p>Folding Side Chair / (Pair)</p> <p>Carton Box : Thick 5 ply carton box Wood : Nyatoh Finishing : PU Teak oil Unit Size : 1.54 x 2.04 x 2.92 ft 46.99 x 62.23 x 88.9 cm</p> <p>Per Carton: 2 - (1 Pair) Carton Size : 3.81 x 1.67 x 0.82 ft / 5.22 cft 116 x 51 x 25 cm / 0.148 cbm</p> <p>GW/NW : 39.68 / 33.07 lbs (19.84 / 16.54 lbs Each) 18 / 15 kgs (9 / 7.56 kgs Each)</p> <p>NMFC: "85" Folding Chairs - Item "80565" - Knocked down in boxes.</p>	<p>Folding Arm Chair / (Pair)</p> <p>Carton Box : Thick 5 ply carton box Wood : Nyatoh Finishing : PU Teak oil Unit Size : 1.79 x 2.04 x 2.92 ft 54.61 x 62.23 x 88.9 cm</p> <p>Per Carton: 2 - (1 Pair) Carton Size : 3.81 x 2.132 x 0.89 ft / 7.19 cft 116 x 65 x 27 cm / 0.204 cbm</p> <p>GW/NW : 44.1 / 37.48 kgs (22.05 / 18.74 lbs Each) 20 / 17 kgs (10 / 8.5 kgs Each)</p> <p>NMFC: "85" Folding Chairs - Item "80565" - Knocked down in boxes.</p>
<p>10" BRELLA VASE</p> <p>Box : Folding Carton Box Size : 0.5625 x 0.8646 x .5 ft / 0.243 cft 17.15 x 26.35 x 15.24 cm / 0.0069 cbm</p> <p>Per Carton: 12 GW/NW : 1 lb 1.9 / 1 lb 0.51 / .454 kgs</p> <p>NMFC:</p>	<p>5" BRELLA VASE</p> <p>Box : Folding Carton Box Size : 0.5 x 0.438 x 0.438 ft / 0.096 cft 15.24 x 13.34 x 13.34 cm / 0.0027 cbm</p> <p>Per Carton: 12 GW/NW : 5.5 / 5 oz 0.156 / 0.141 kgs</p> <p>NMFC:</p>
<p>BRELLA LIGHTS - PATIO UMBRELLA LIGHTING SYSTEM / (8 Rib)</p> <p>Box : E-Flute Box Size : 1 x 1 x .25 ft / 0.25 cft 30.48 x 30.48 x 7.62 cm / 0.007 cbm</p> <p>Per Carton: 12 GW/NW : 2.125 lb 0.096388 kgs</p> <p>NMFC: "100" Lights Item "109886"</p>	

9 Ft. OFF-THE-WALL BRELLA™ - (Cat. No. OTWB9) // SHOWN WITH CUSTOM CAST BASE - (CCB-2)

FRONT VIEW

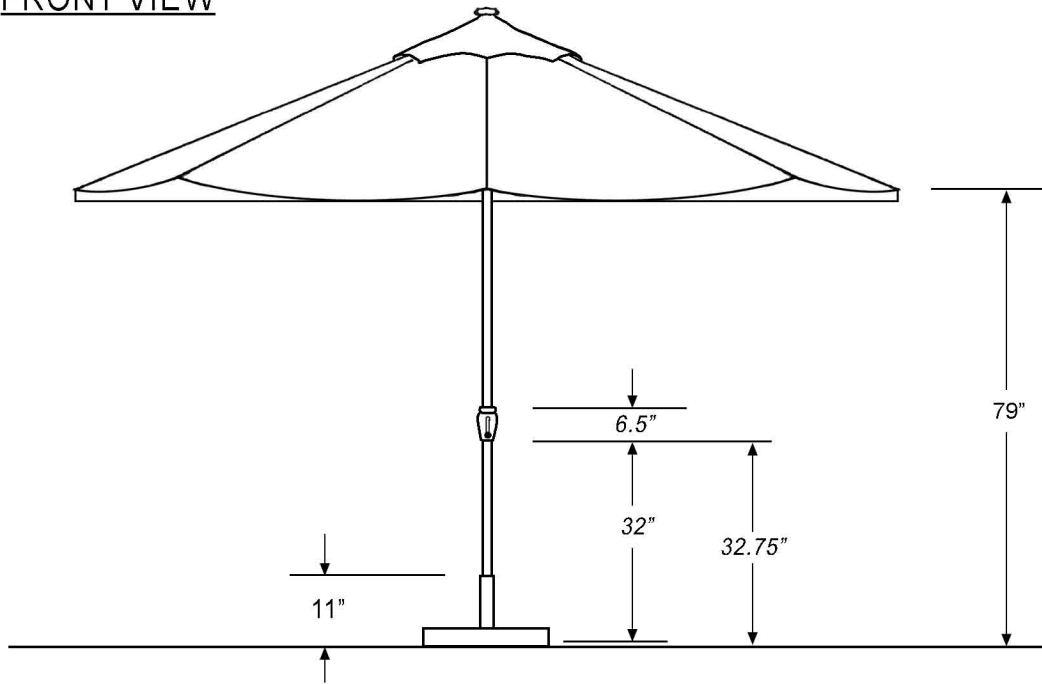

SIDE VIEW

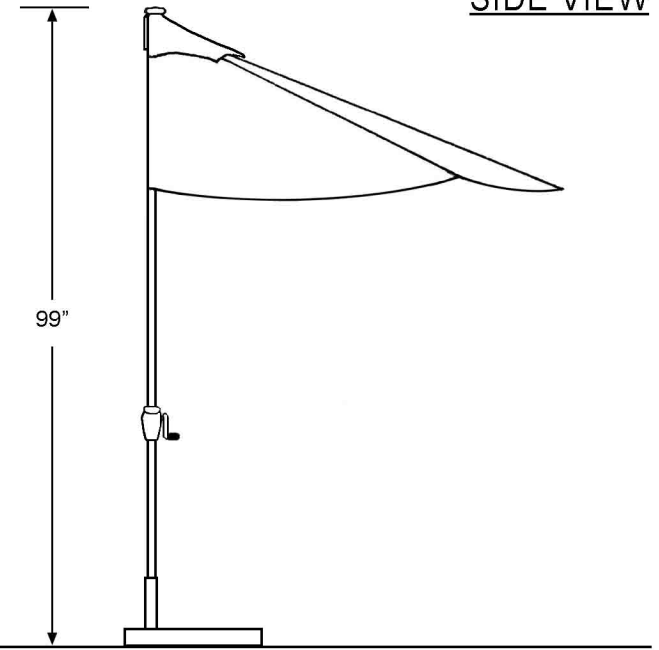

TOP VIEW

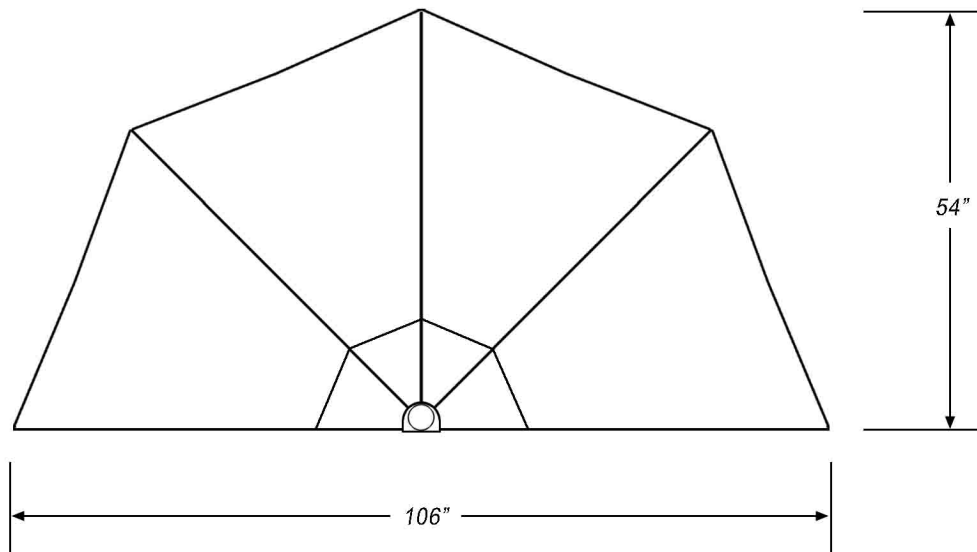

- Aluminum Frame
- Powder Coat Finish
- 1½" O.D. Pole
- Crank Lift Canopy
- Champagne Color
- Finial
- Wall Bumper



(800) 293-2323

7.5 Ft. OFF-THE-WALL BRELLA™ - (Cat. No. OTWB7) // SHOWN WITH CUSTOM CAST BASE - (CCB-2)

FRONT VIEW

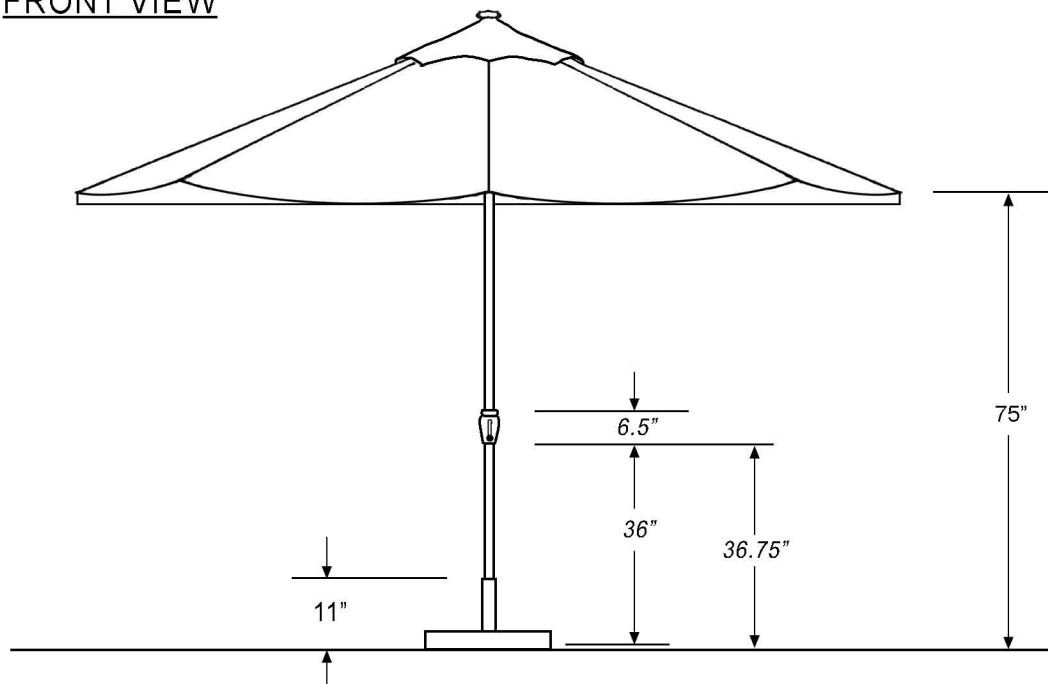

SIDE VIEW

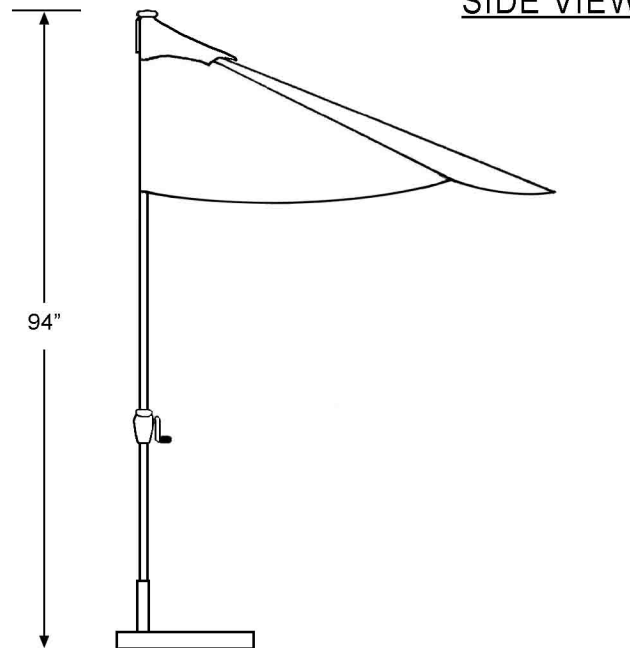

TOP VIEW

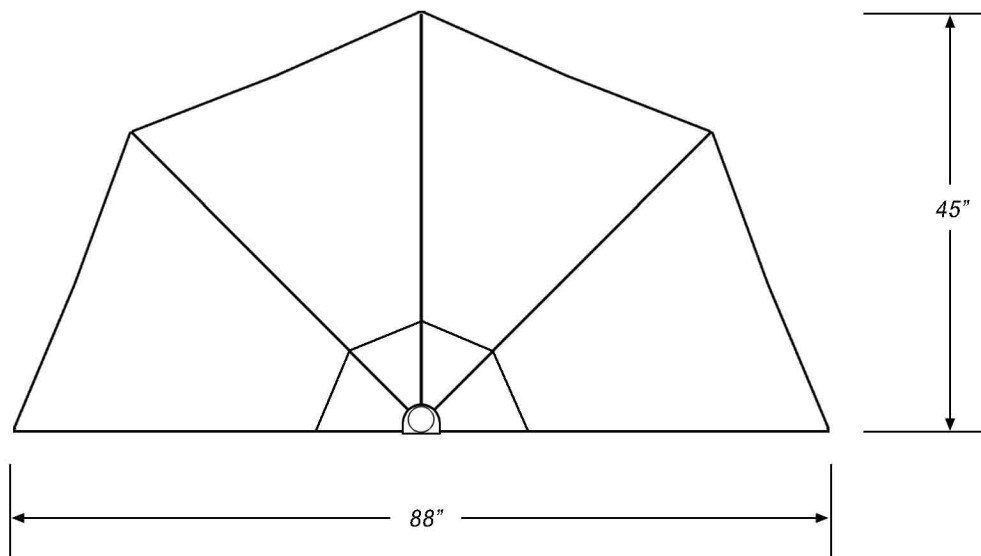

- Aluminum Frame
- Powder Coat Finish
- 1½" O.D. Pole
- Crank Lift Canopy
- Champagne Color
- Finial
- Wall Bumper



(800) 293-2323

CUSTOM CAST BASE - (Cat. No. CCB-2)

FRONT VIEW

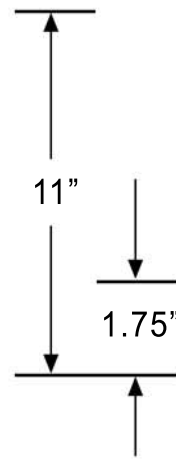
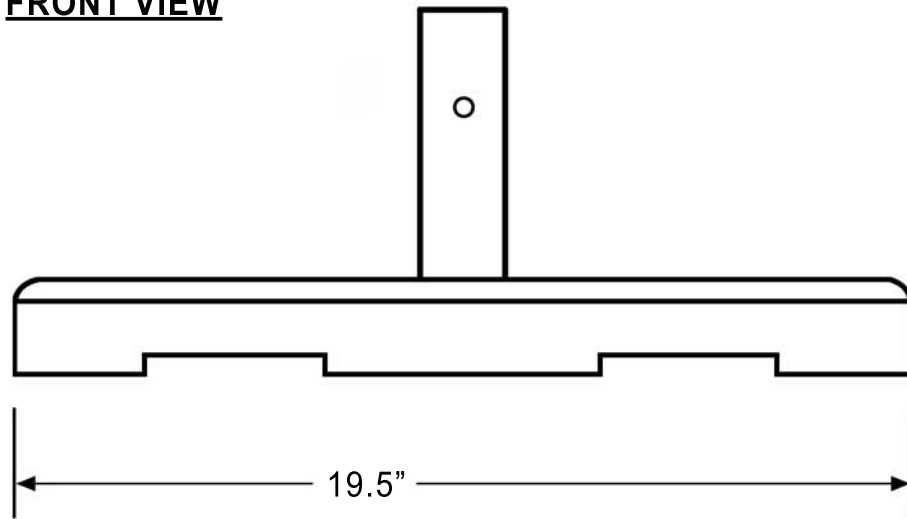

SIDE VIEW

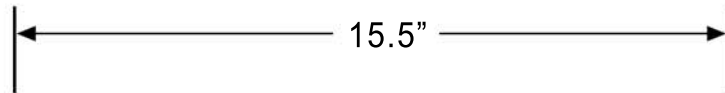
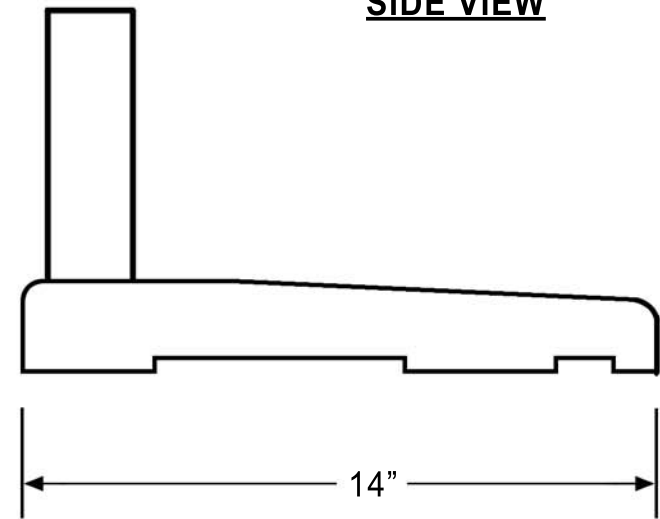

TOP VIEW

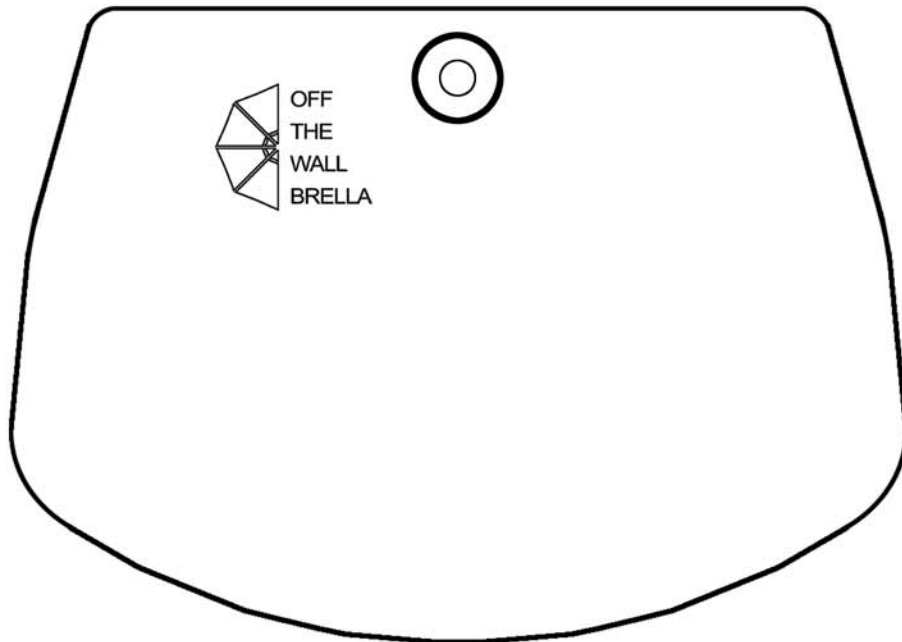

- 40 Pound Weight
- Cast Iron
- Powder Coat Finish
- Champagne Color
- Stand Tube
- Pole Cinch Knob
- Tilt Adjusters



(800) 293-2323

www.BlueStarGroup.BIZ